



*An Online PDH Course
brought to you by
CEDengineering.com*

Designing Traffic Signals

Course No: C03-023

Credit: 3 PDH

Jeffrey W. Buckholz, Ph.D., P.E., PTOE



Continuing Education and Development, Inc.

P: (877) 322-5800

info@cedengineering.com

www.cedengineering.com

DESIGNING TRAFFIC SIGNALS

This Traffic Signal design course describes principals used in the design of traffic signals. Included in this course is a discussion of support selection, signal head placement, detection design, and the selection of signal control and timings.

After collecting the needed data and completing the necessary planning tasks, the final design plans for the traffic signal installation are prepared. Prior to initiating the design work, it is very important that the designer visit the site so that he or she can have an accurate visual image of the design environment. More than one site visit will typically be required to fully understand the traffic operations environment of the intersection in question. At the very least, a visit should be made during both the weekday AM peak hour and the weekday PM peak hour. If the intersection is in close proximity to a special traffic generator, such as a school or factory, a site visit during the entrance and exit times of the generator will also prove valuable. A night visit is also a good idea.

The type of intersection to be controlled has a pronounced effect on the design that is developed. Although standard 4-leg intersections are the norm, there are many other types of intersections that, in one respect or another, require special treatment:

- 5-leg Intersections
- "T" Intersections
- Skewed Intersections
- Staggered Intersections
- Freeway Ramps
- Intersections with Frontage Roads
- Single Point Urban Interchanges

The initial step in developing a traffic signal design is the preparation of an accurate base plan. Ideally, a base plan is prepared using field survey information supplemented by information contained on the condition diagram. If a complete field survey cannot be conducted, either for cost or time reasons, then a base plan can be prepared using the condition diagram along with existing construction plans or aerial photographs. Although this approach may be less accurate than a comprehensive field survey, it will also be less costly. The base plan should include all relevant geometric and topographic features of the intersection, including curb lines, median locations, driveways, sidewalks, and utilities.

Since signal equipment cannot be located on private property without special permission from the property owner, right-of-way lines also need to be shown on the base plan. Unless old plans with right-of-way information can be obtained, establishing accurate right-of-way lines will probably require the assistance of a registered land surveyor.

Regardless of which method is chosen for preparing the base plan, the final plan will need to be "to-scale". A to-scale plan is one where a dimension on the plan directly corresponds to a dimension on the ground. For example, on a base plan prepared at a scale of 1-to-20 (1 inch equals 20 feet), a road that is 40 feet wide will be 2 inches in width on the base plan.

Common base plan scales for traffic signal design are 1-to-20, 1-to-40, and 1-to-50. Plans prepared to these scales are also referred to as 20 scale, 40 scale, and 50 scale plans.

The smaller the scale number, the larger a given item will appear on a plan sheet. For example, an item on a 20 scale plan appears 2.5 times larger than the same item on a 50 scale plan. For this reason, 20 scale plans are frequently referred to as "large scale" plans while 50 scale plans are called "small scale" plans. The advantage of large scale plans is that they show features more clearly but the disadvantage is that they require a bigger sheet to display a given drawing.

In order to avoid confusion when discussing the layout of an intersection, proper directional terminology should be used. For example, vehicles arriving at an intersection from its north leg are said to arrive on the "north approach" or, alternatively, the "southbound approach". Vehicles arriving at the intersection from the east leg are said to arrive on the "east approach" or, alternatively, the "westbound approach".

The first design question that needs to be answered is whether or not pedestrian features (crosswalks, pedestrian heads, and pedestrian buttons) will be needed at the intersection under study. All other things being equal, it is usually much easier to design traffic signals for intersections that do not require pedestrian features.

If the intersection has sidewalks, or a significant amount of pedestrian activity, pedestrian features will probably be required. In this case, the signal design should begin with the design of the pedestrian crossing system.

Where possible, crosswalks should be located to match up with existing sidewalks:

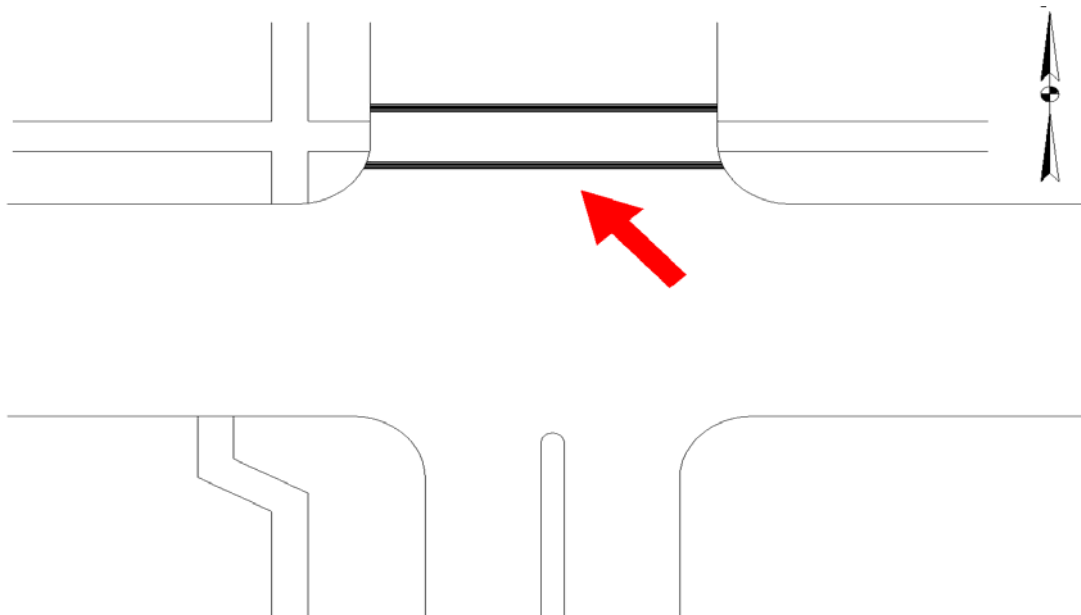

Crosswalk lines are typically 1 foot in width. Special emphasis crosswalks may be used at locations requiring increased conspicuity:

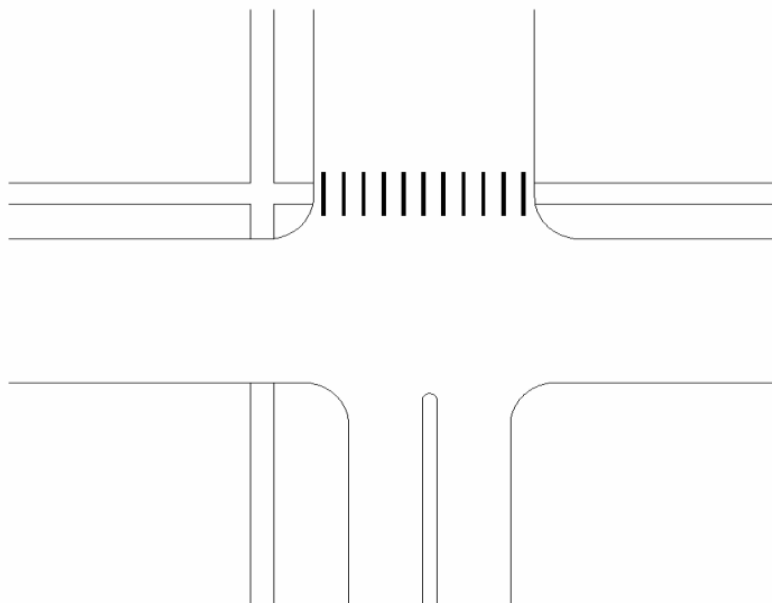

In order to form a continuous pedestrian system the addition or relocation of sidewalk segments may be required:

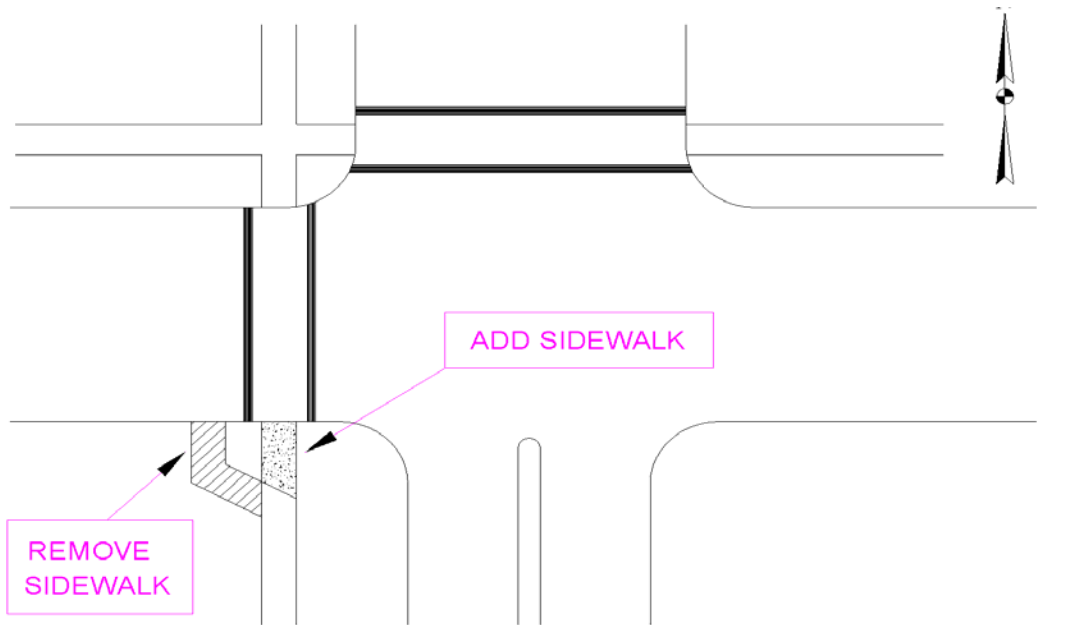

With the sidewalk and pedestrian crosswalk locations set, the next task is to locate the stop lines and associated lane lines and pavement arrows. Stop lines are white in color, typically 2 feet in width, and are usually located 4 feet behind any pedestrian crosswalk lines that exist:

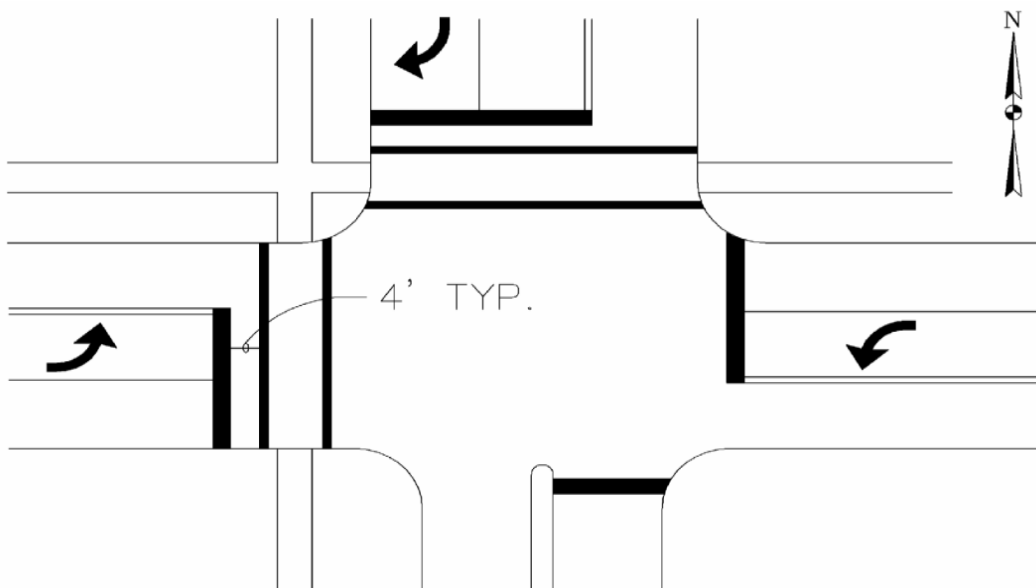

The "TYP." indication on a set of plans means "typical". In this case it means that all stop lines located behind crosswalks should be 4 feet away. It is always desirable to place the stop line behind the crosswalk; otherwise pedestrians will be required to cross between vehicles and crossing between vehicles is not considered a safe practice. When locating stop lines it is also desirable to place them as close as possible to the "natural" location at which drivers want to stop:

GOOD LOCATION

POOR LOCATION

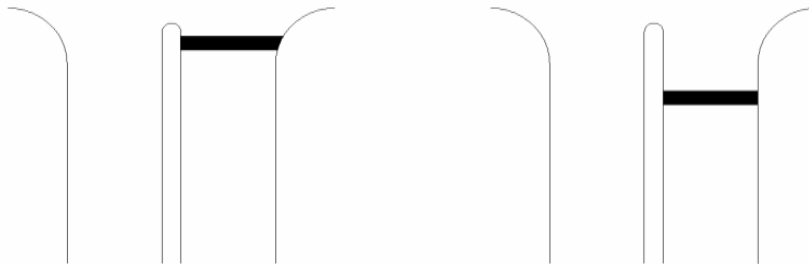

A stop line location close to the end of a median nose is a more natural stopping position than one some distance from the median nose. Not locating stop lines in their natural position will result in some drivers pulling past the stop line.

Having located the crosswalks and stop lines, the next step in the design process is to select the signal indications for each approach. As part of the signal planning process the phasing of the intersection was determined, so the designer must now simply select the indications which best communicate the desired phasing. Continuing our example, protected-only left turn phasing has been added to the west approach:

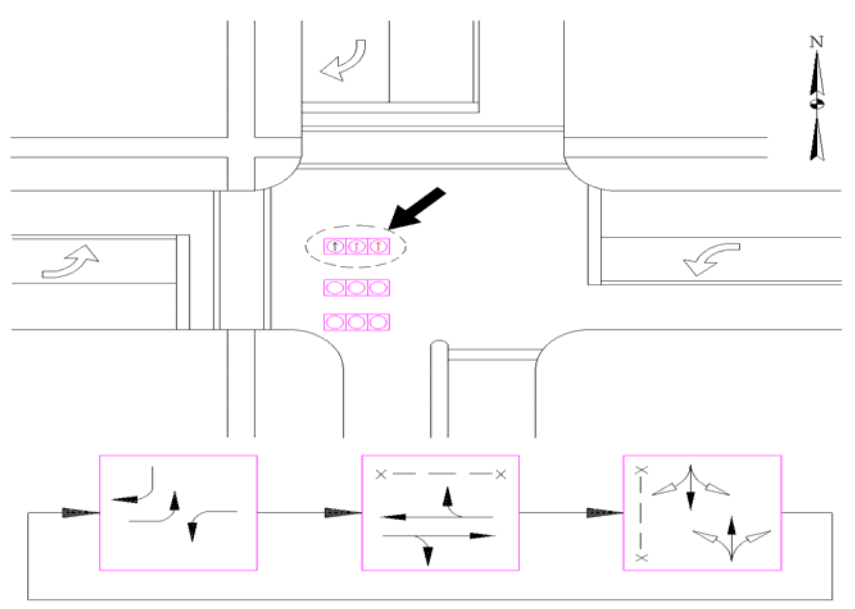

Protected-permissive left turn phasing has been added to the east approach:

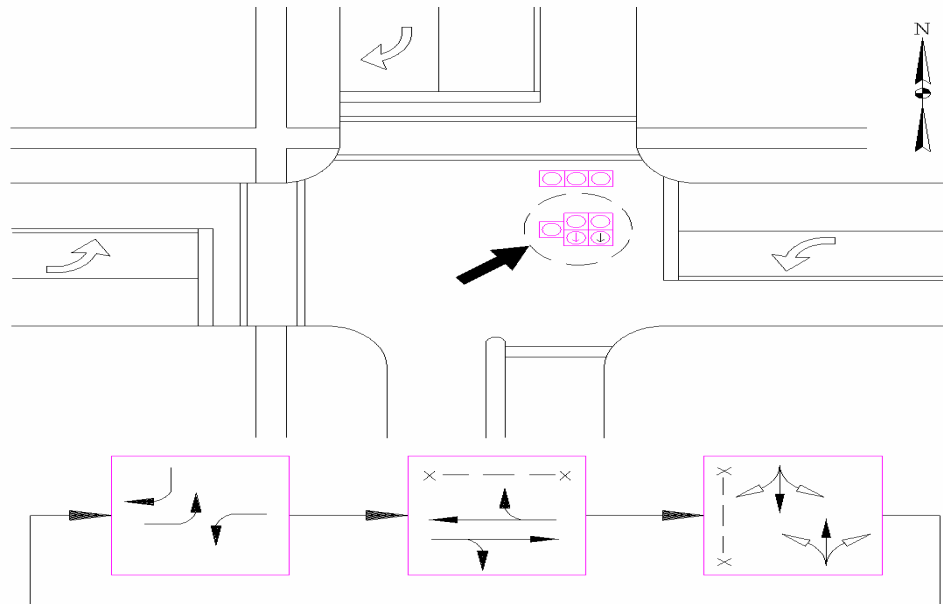

And a right turn overlap phase has been added to the north approach:

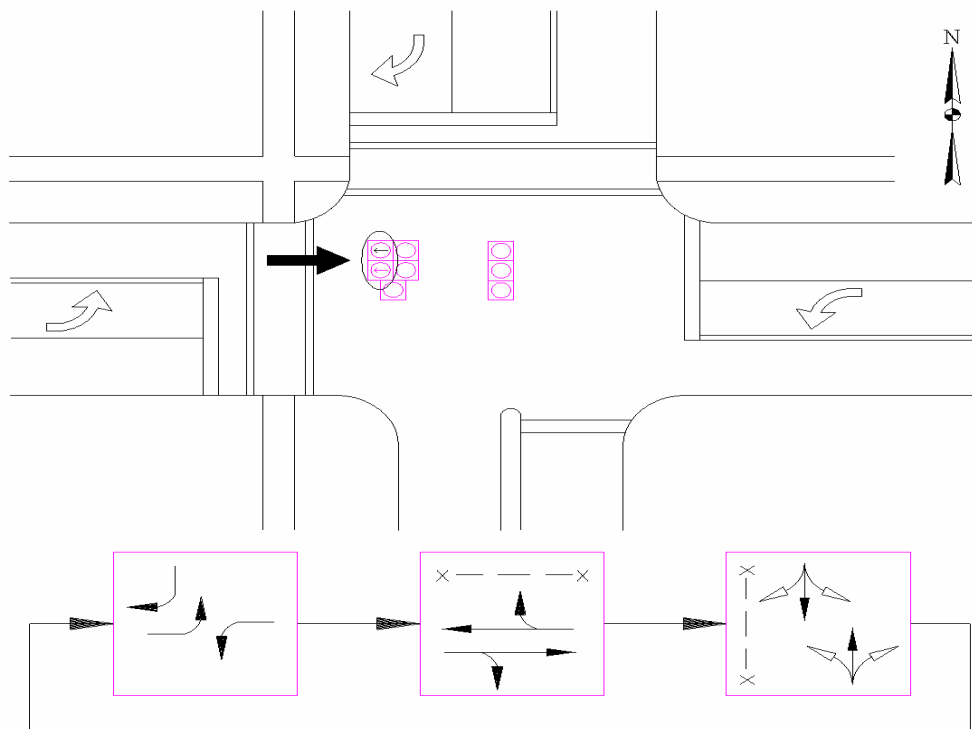

The south approach has no special turn phases:

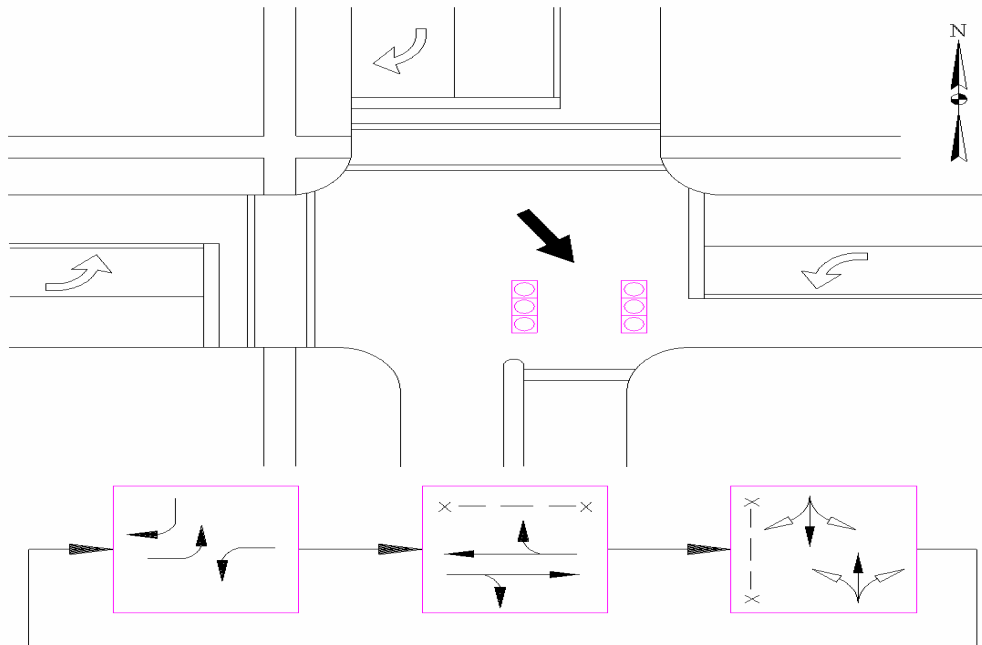

The phasing diagram at the bottom of these drawings depicts how the signal will operate. First the major street turns will be given the green indication:

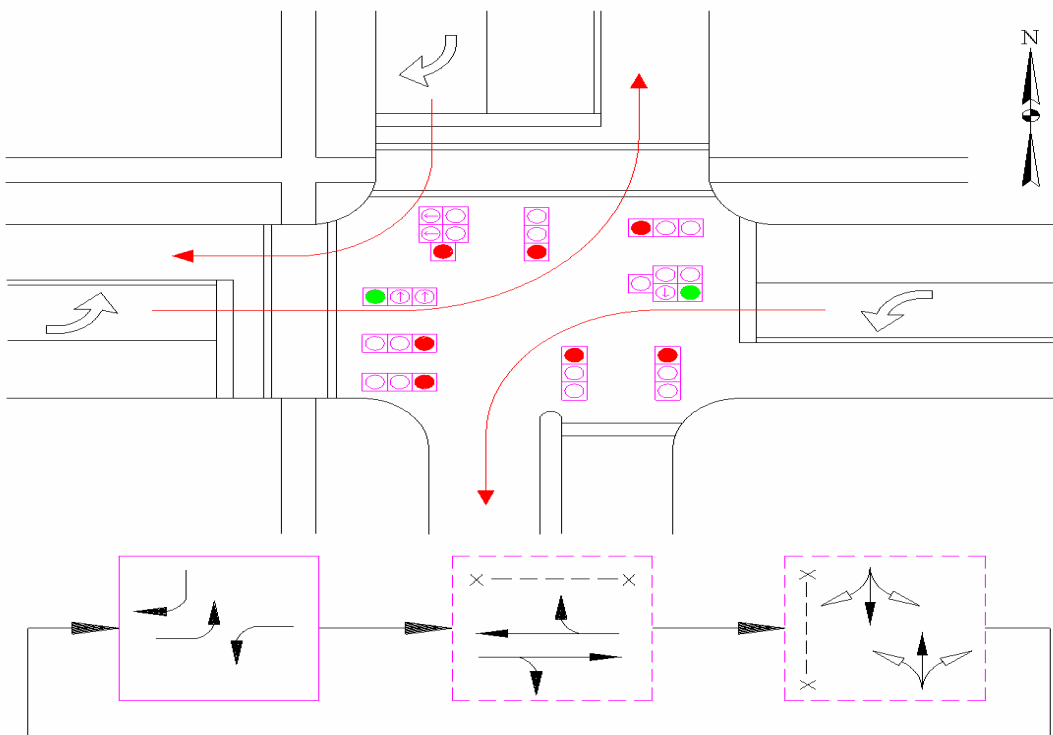

Then the major street thru movements will receive the green:

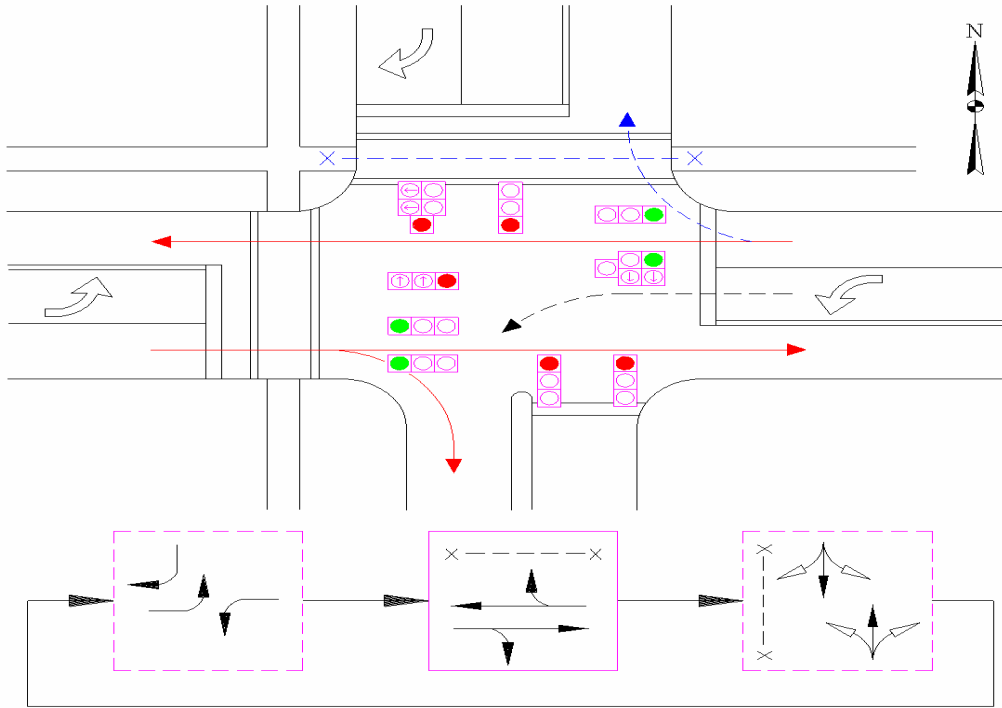

And finally the side street thru movements will have the green:

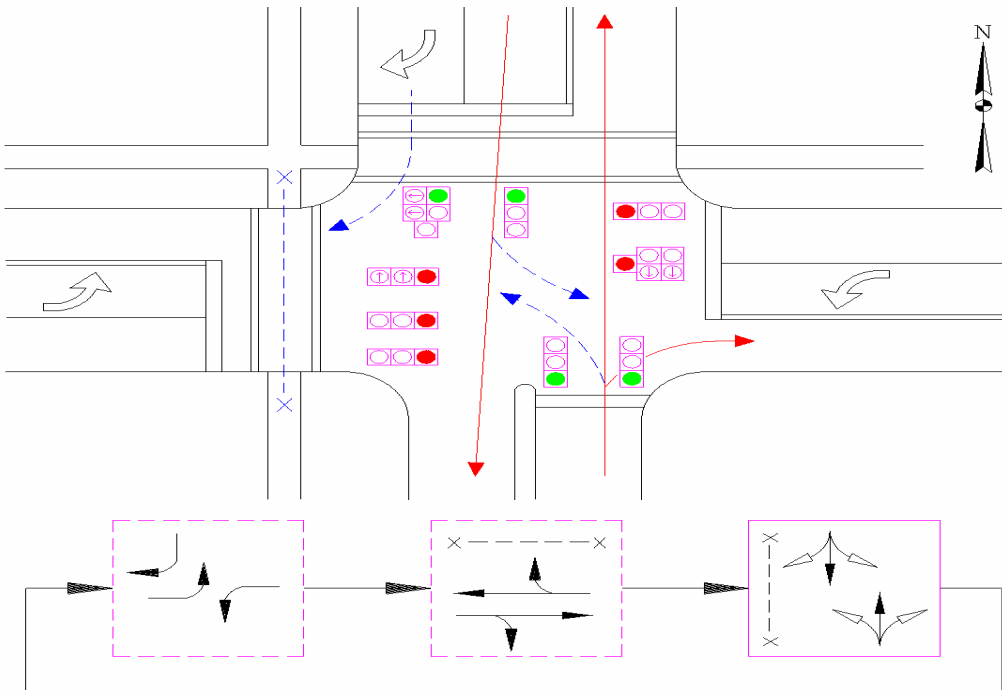

Note that all thru movements in this example are controlled by at least two signal indications:

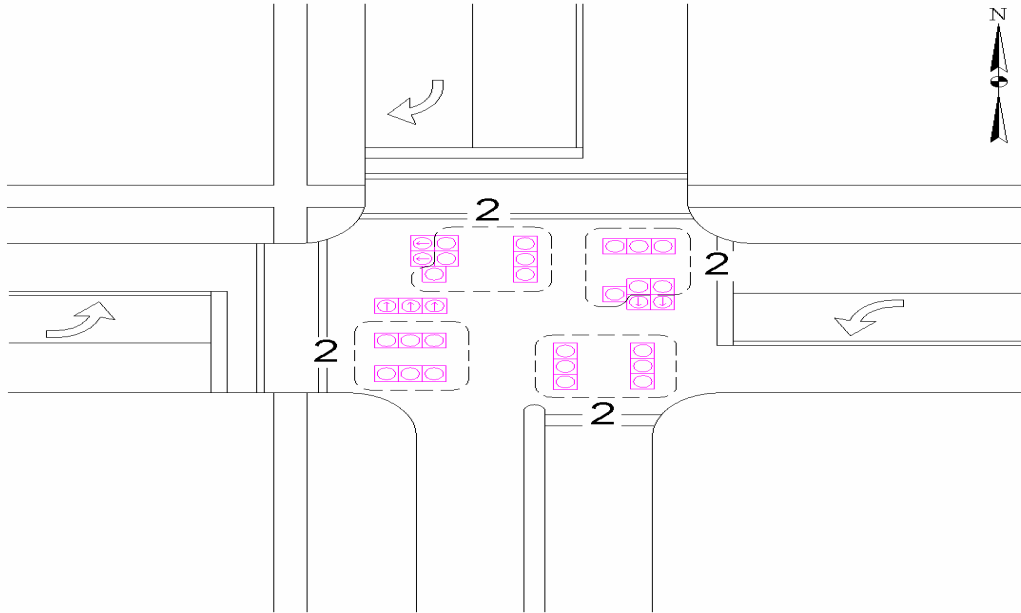

This is a requirement of the MUTCD.

The protected/permissive signal head controlling the east approach left turn in this example is referred to as a 5-section cluster. An alternative to the use of a 5-section cluster is what could be called a "straight 5" head. When a 5-section cluster is used it is standard practice (although not strictly required) to center the cluster over the lane line separating the left and thru lanes:

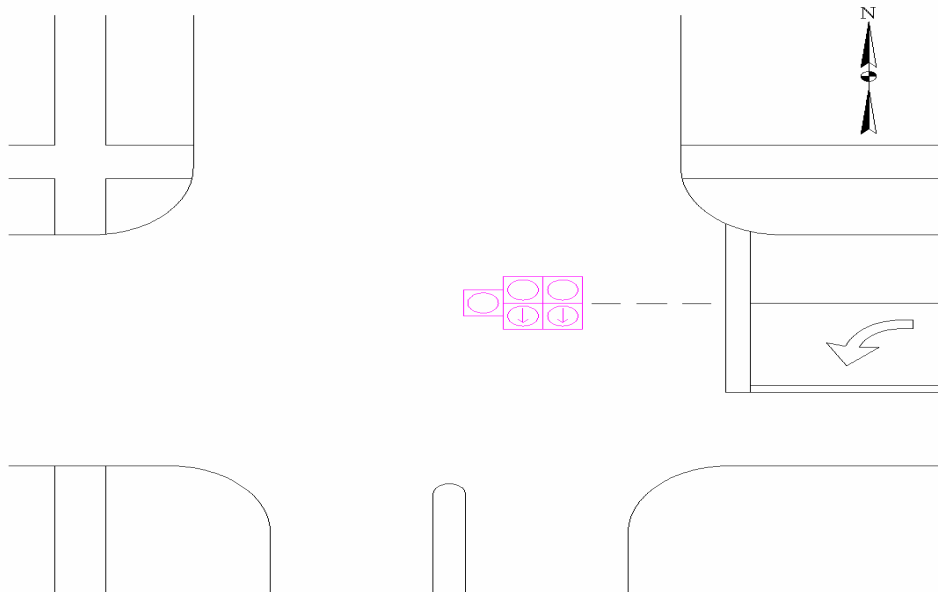

When a "straight 5" signal head is used the head is typically centered in the left turn lane.

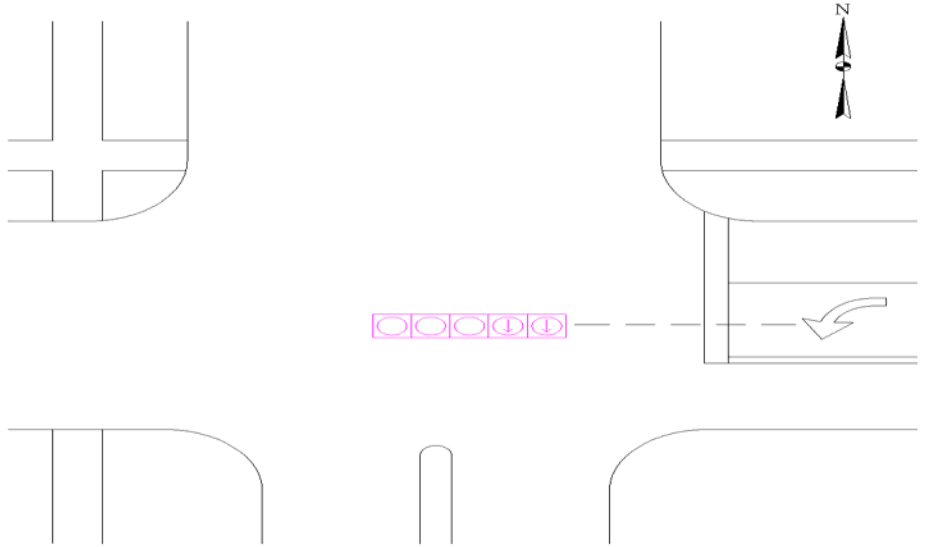

The MUTCD has a number of restrictions concerning where traffic signal heads may be placed. Essentially, the MUTCD requires that at least one signal head controlling a particular movement be located within the shaded area shown in the following graphic:

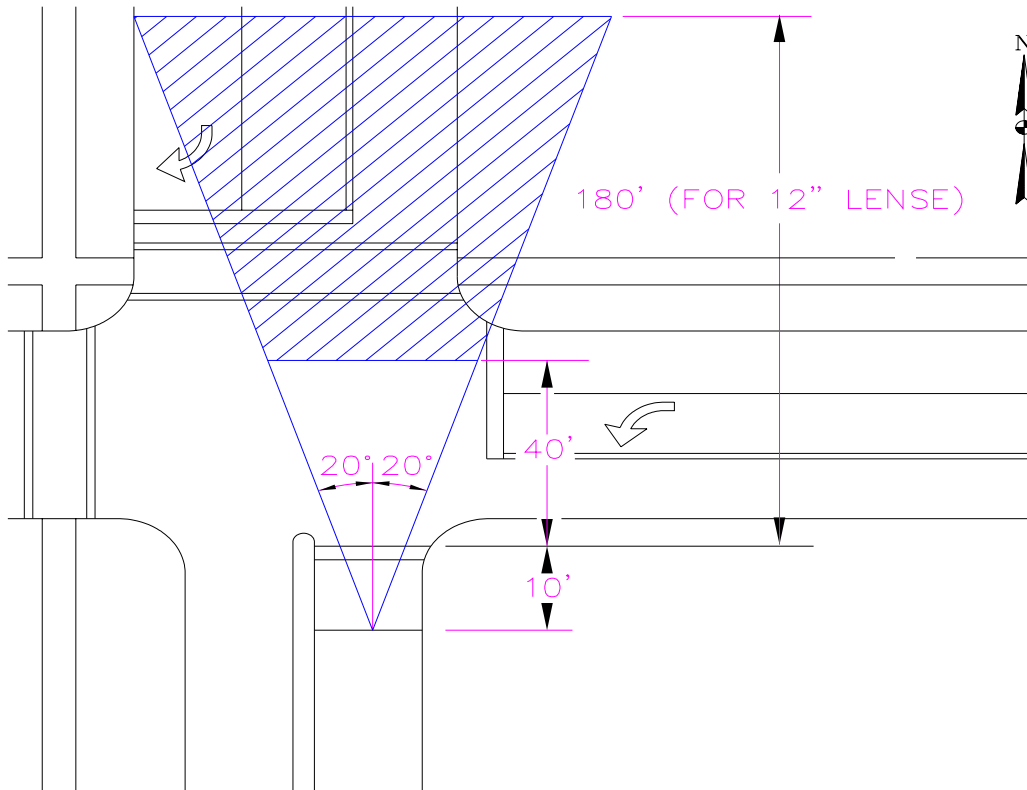

The desired signal head arrangement could be achieved using a number of different signal support configurations, including pedestal mounted signal heads:

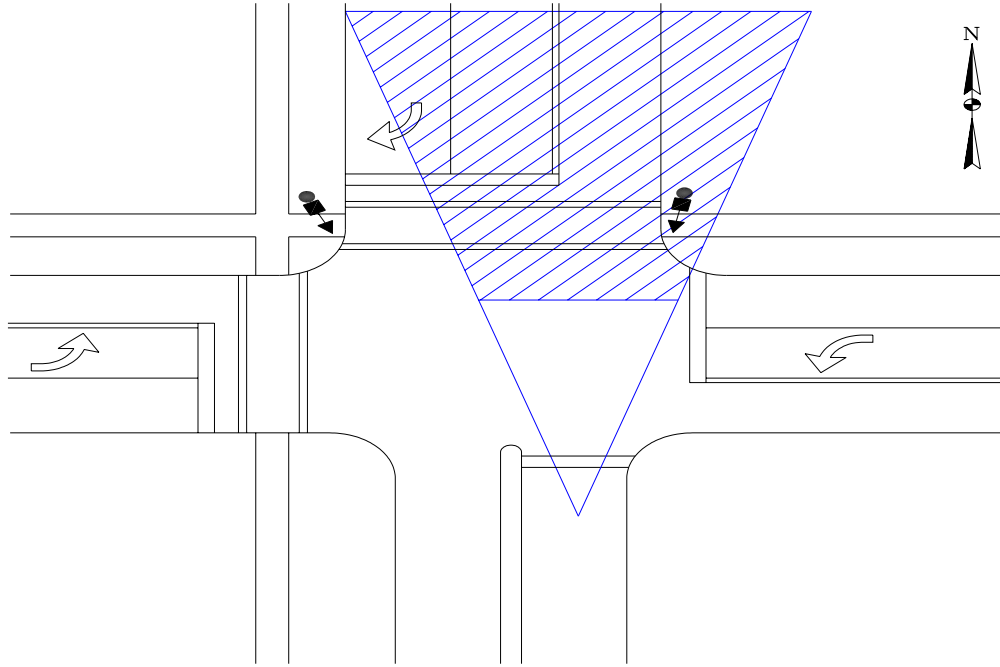

Mast arm mounted signal heads:

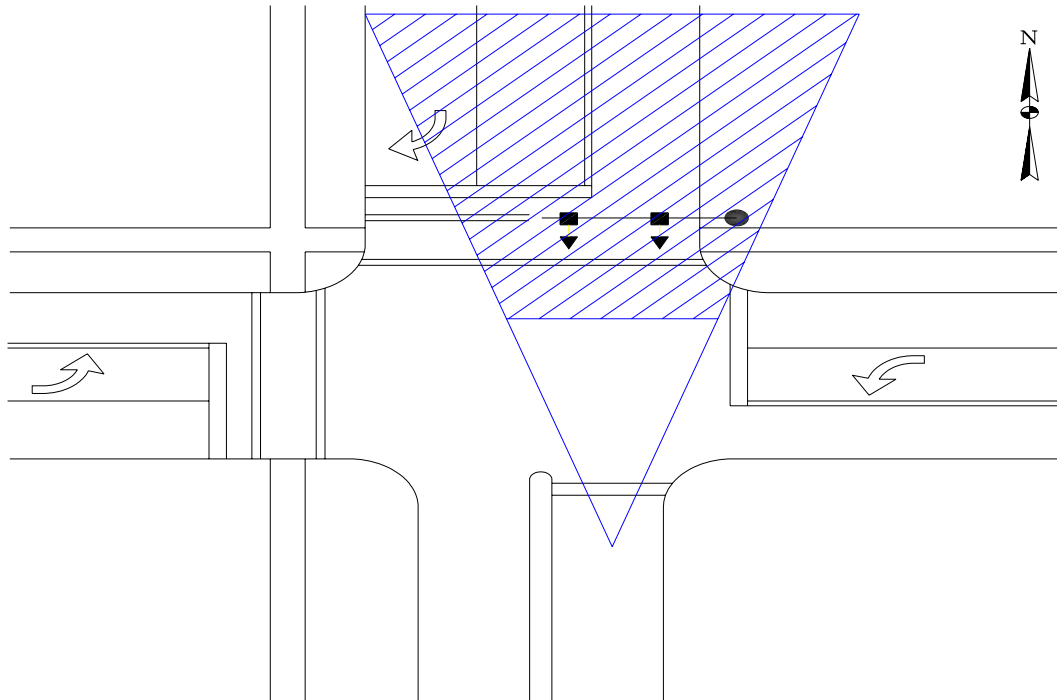

Concrete or wooden strain poles configured as a box span:

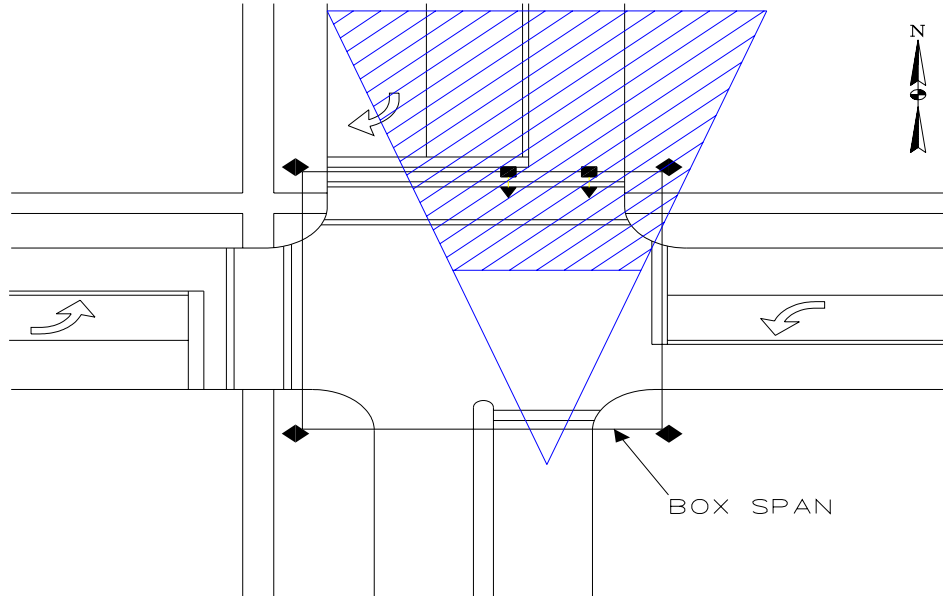

Or strain poles configured as a diagonal span:

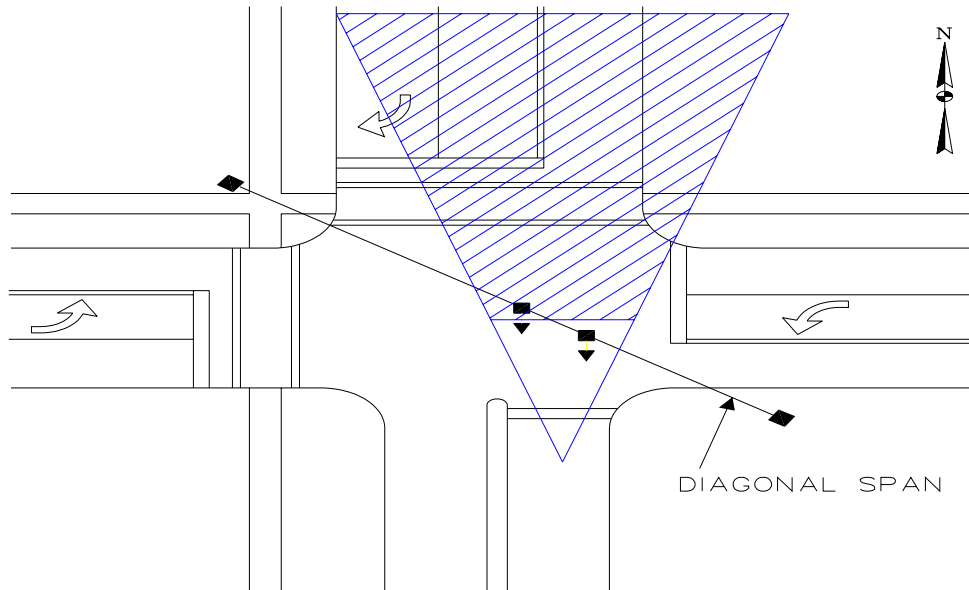

Notice that, in this example, only 1 of the 2 heads is within the acceptable viewing area if pedestals or a diagonal span is used. This is allowable, but not preferred. The designer's decision on where to place the signal heads is intimately tied to the type of support structure to be used. If for some reason the type of support structure is fixed in advance (such as under an airport glide path where only pedestal mounted signals might be allowed), then signal head location options will be limited

accordingly. Signal head placement must also consider sight distance requirements for approaching traffic. If the previous example is modified to include a severely curved approach, then at least one more signal head would be added:

SIGHT DISTANCE REQUIREMENTS

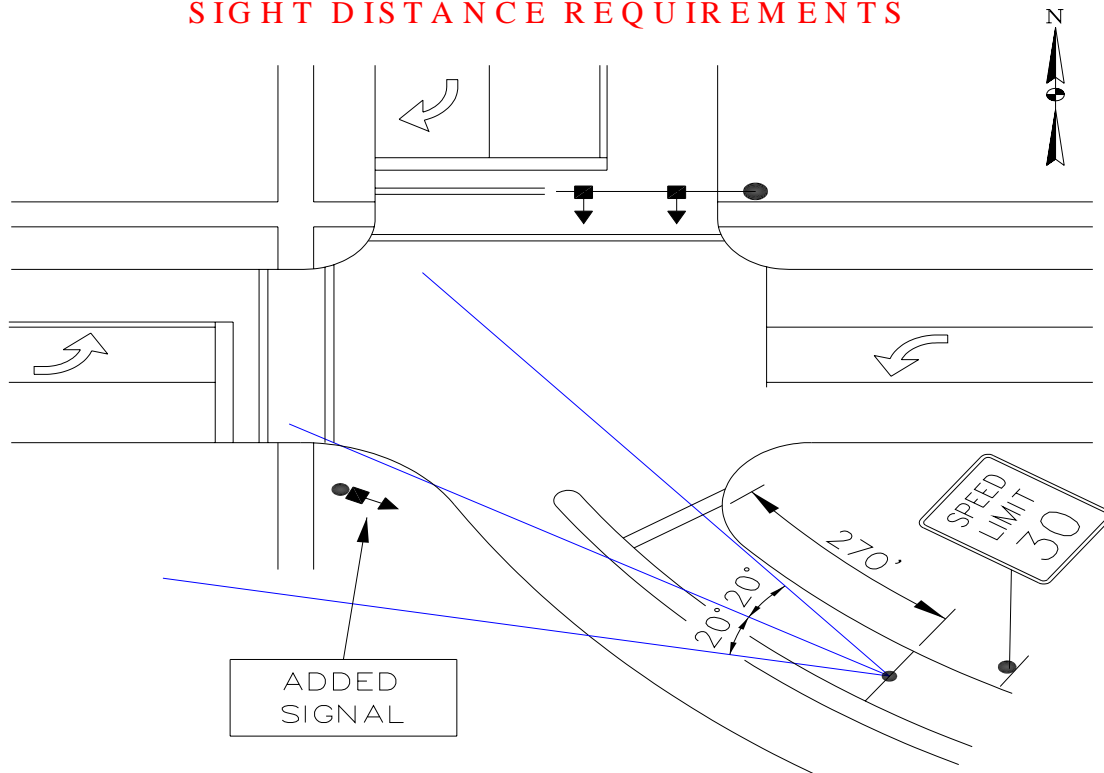

This drawing shows the use of a supplemental near side signal head to meet sight distance requirements. Supplemental near side signal heads are also useful when the "normal" heads are too far away from the stop line, or when a vertical sight restriction (such as an overpass) obscures the overhead signal indications.

Although it is best to locate the stop lines first and then situate the signal heads, physical restrictions at an intersection sometimes require that an iterative process be used. We may be forced to locate the stop line in a "less than natural" location in order to meet the signal head distance requirements of the MUTCD.

If mast arms are chosen as the means of signal support then the foundation for the mast arm pole will need to be designed by a structural engineer. As the length of the mast arm increases, and as the number of items attached to the arm increases, the size of the foundation typically increases. In order to properly design the foundation, the structural engineer will usually request that a soil boring be taken at each proposed pole location. Poor soil conditions necessitate the use of larger and more

costly mast arm pole foundations. A structural engineer will also be needed to design the mast arm itself, sizing such items as wall thickness, bolt diameters, and base plate dimensions.

Signs and backplates have a pronounced effect on the size of the mast arm assembly that is required since these items have large surface areas and are capable of incurring high wind loadings. It is typically wind, not weight, that increases the size (and associated cost) of mast arm poles and their foundations.

Various sizes and strengths of strain poles are manufactured and it is the designer's responsibility to select the pole that meets the situation at hand. Some agencies have developed computer programs that help the designer select the correct size and type of strain pole. If strain poles are chosen as the means of signal support then the designer will need to make sure that the support wires do not come too close to overhead electric lines. Although each electric company has its own set of guidelines, a typical rule-of-thumb is that no support wire can be within 40 inches of a primary electrical line:

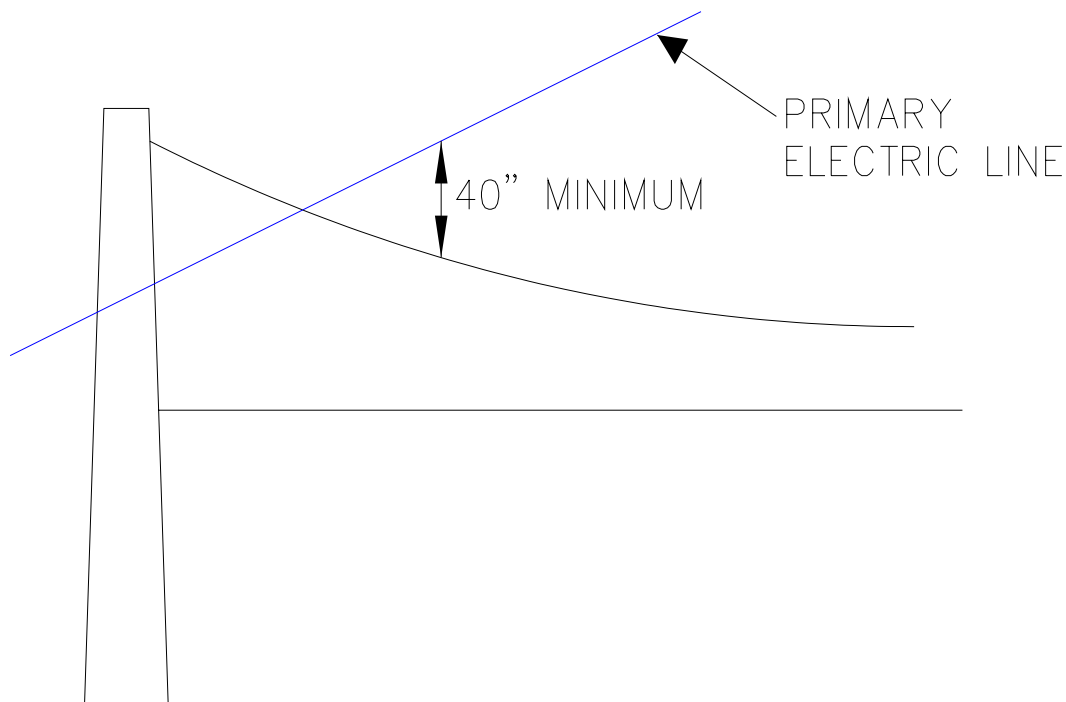

If this distance cannot be provided then a design change or utility relocation will be needed.

In order to design the height of overhead signal support structures it is necessary to determine the ground elevation at each proposed pole location and at the crown of the road over which the signals will be situated:

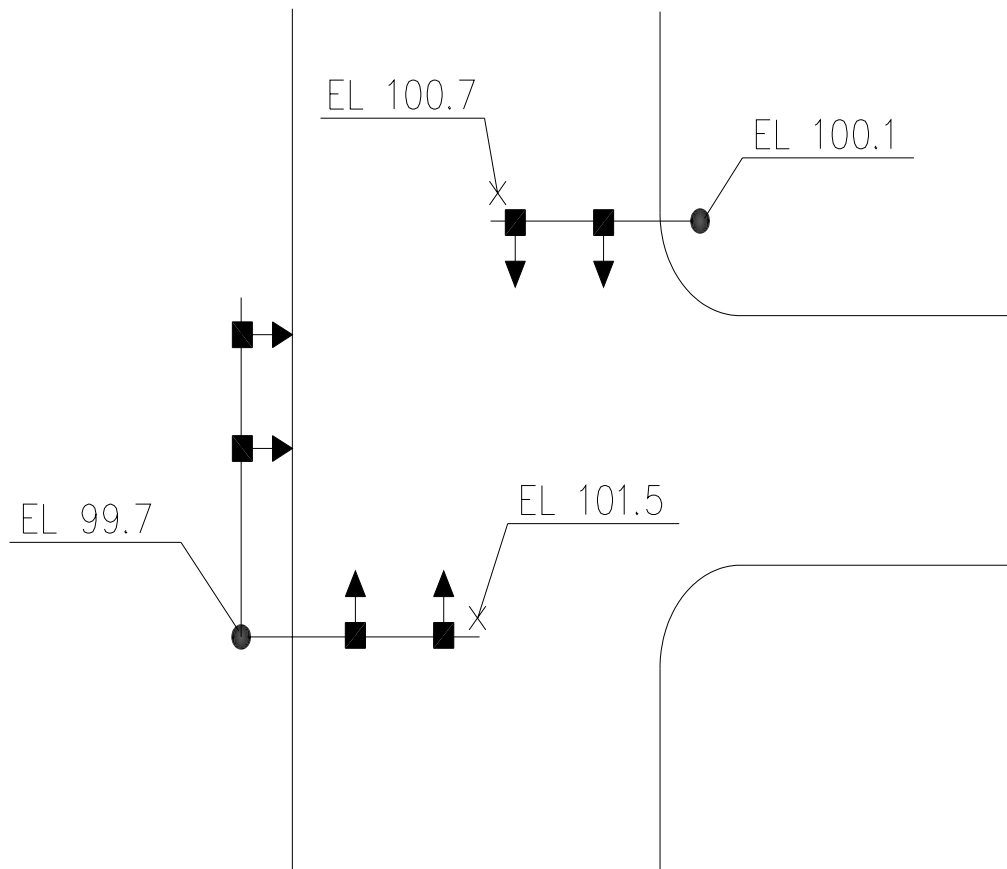

This can either be done as part of the initial survey work or, in a cruder fashion, using a hand level.

Pedestals are typically constructed using standard dimensions and details; a structural design effort is seldom required.

When designing or selecting a set of signal supports, it is wise to plan for potential future expansion of the signal installation. For example, it is not uncommon for left turn traffic at an intersection to increase over time such that a left turn signal is needed where permissive control was once adequate. If the original signal support was not designed to be long enough and strong enough to support the additional signal head, then a costly re-build will be required.

Pedestrian heads and buttons should be properly located with respect to the crosswalk. To the maximum extent possible, heads should be aligned with the crosswalk while pushbuttons should be conveniently located with respect to the approaching sidewalk:

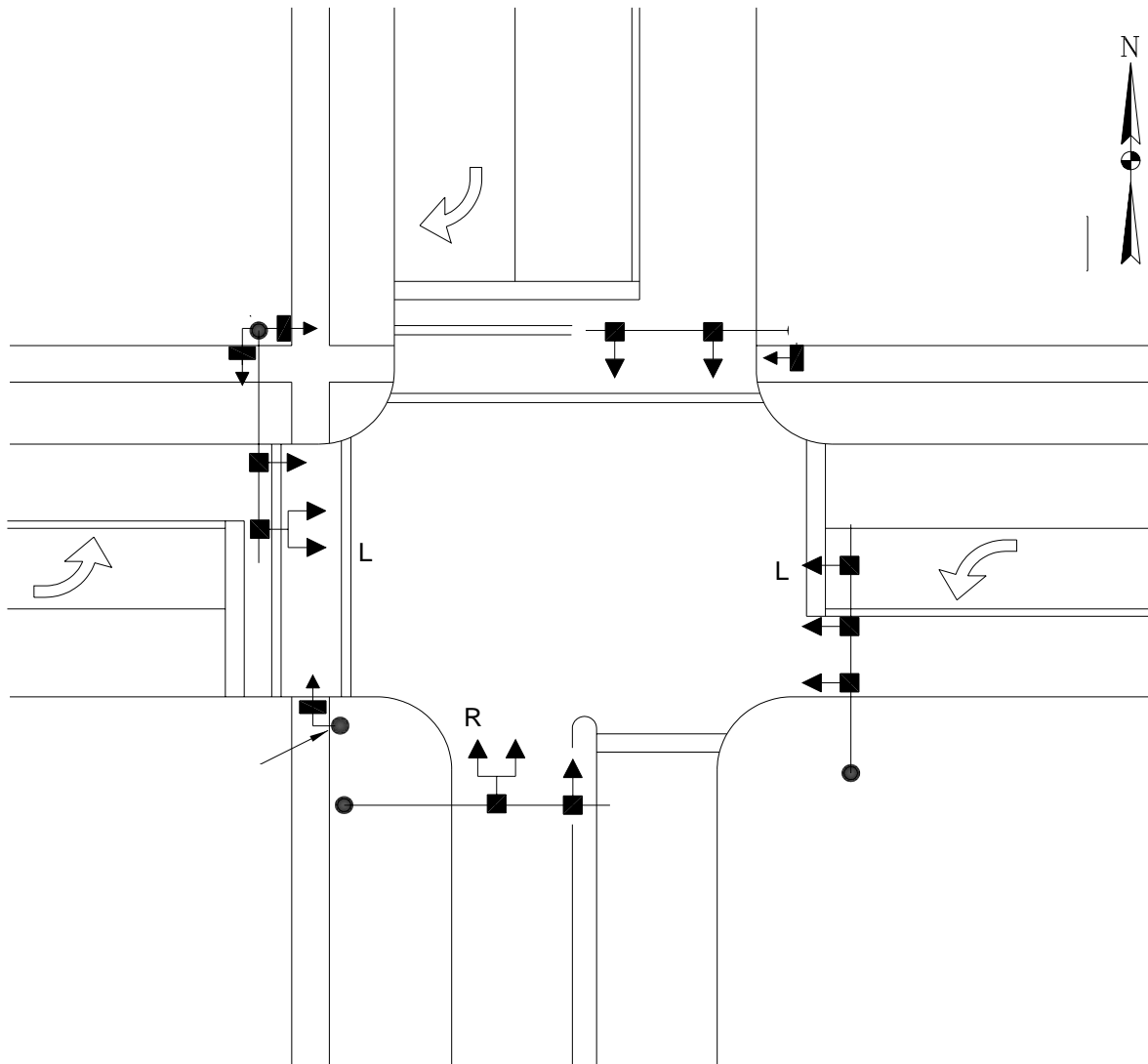

Note that, in this example, a separate pedestrian pedestal has been added to the southwest corner because the mast arm on this corner is too far away from the crosswalk to house the pedestrian head and pushbutton.

The MUTCD provides the following graphic which illustrates the desired placement of pedestrian buttons.

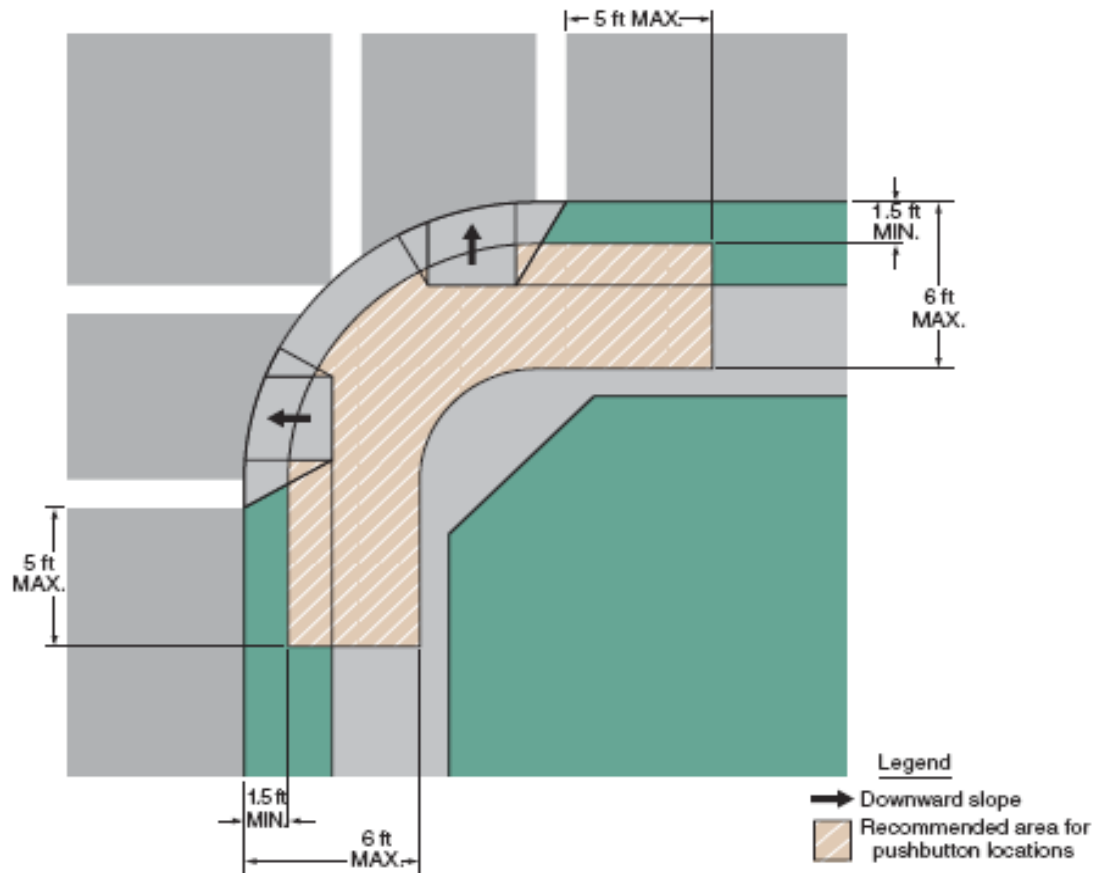

Notes:

1. Where there are constraints that make it impractical to place the pedestrian pushbutton between 1.5 feet and 6 feet from the edge of the curb, shoulder, or pavement, it should not be further than 10 feet from the edge of curb, shoulder, or pavement.
2. Two pedestrian pushbuttons on a corner should be separated by 10 feet.
3. This figure is not drawn to scale.
4. Figure 4E-4 shows typical pushbutton locations.

The basic idea is to keep pedestrian pushbuttons close to the crossing that they serve and at least 10 feet away from other pedestrian pushbuttons. At urban intersections with tight turning radii, it is a good idea to place the pedestrian heads on the back-side of the signal support pole to keep turning trucks from shearing them off.

MOUNT HEADS HERE:

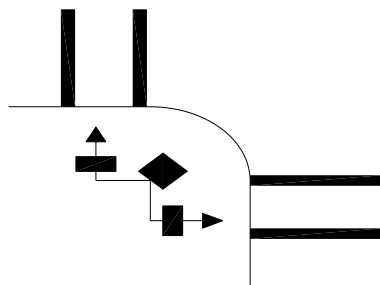

NOT HERE:

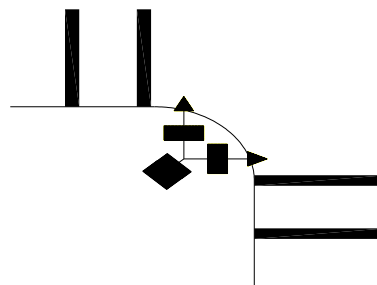

Some states require the designer to determine the number and size of conductors required to serve all of the vehicular and pedestrian heads at an intersection. The designer does this by completing a series of voltage drop calculations. A detailed wiring diagram is then provided as part of the plan set. Other states use standard specifications to identify the number of conductors required for a given situation. In these states no design work is required by the engineer and the responsibility for providing the right size and number of conductors falls to the signal contractor. Regardless of which method is used, enough spare conductors should be provided to accommodate potential future expansion, such as the addition of a left turn signal head.

Three basic types of signal control are available:

1. Pretimed Control
2. Semi-Actuated Control
3. Fully-Actuated Control

Most modern signal controllers are capable of providing all three types of signal control. Under pretimed control, the green time for the various phases can be varied by time-of-day, but not from cycle to cycle. During a given time of the day, such as the AM rush hour, the green time provided to each phase is fixed - regardless of the amount of vehicular demand:

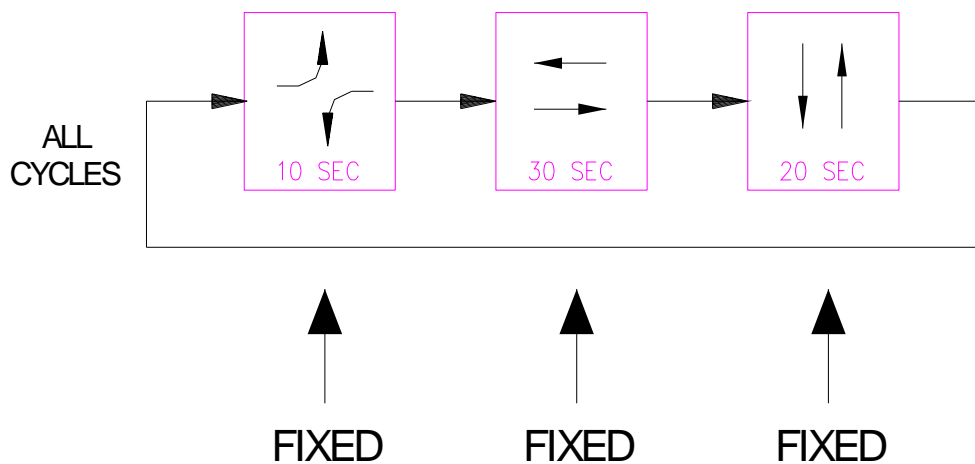

Under fully-actuated control, the green time for the various phases can vary both by time-of-day and from cycle to cycle:

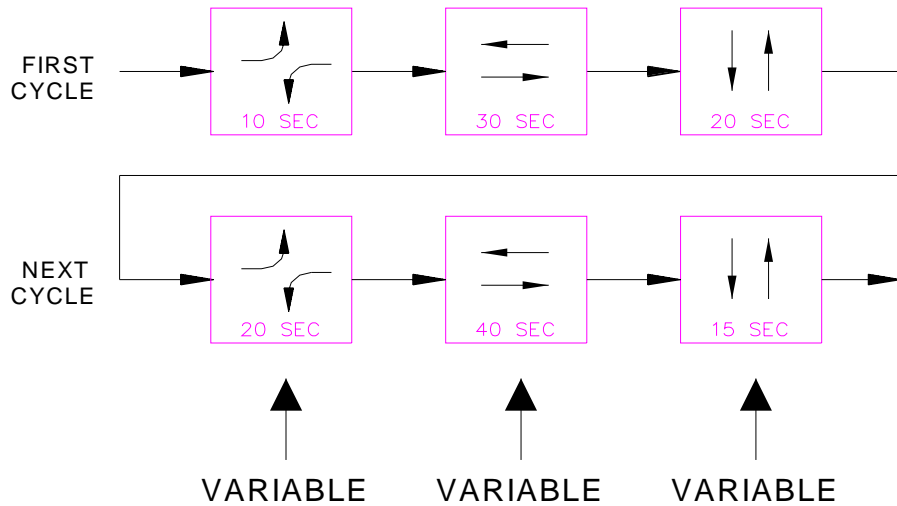

During a given time of the day, such as the AM rush hour, the green time provided to each phase can increase or decrease depending on the amount of vehicular demand. Vehicle demand at a fully-actuated signal is monitored by detection devices located on the various approaches to the intersection.

Under semi-actuated control, green time for the side street phases and the main street left turn phases can vary by time-of-day and cycle to cycle, however, green time for the major street thru movement can only vary by time-of-day:

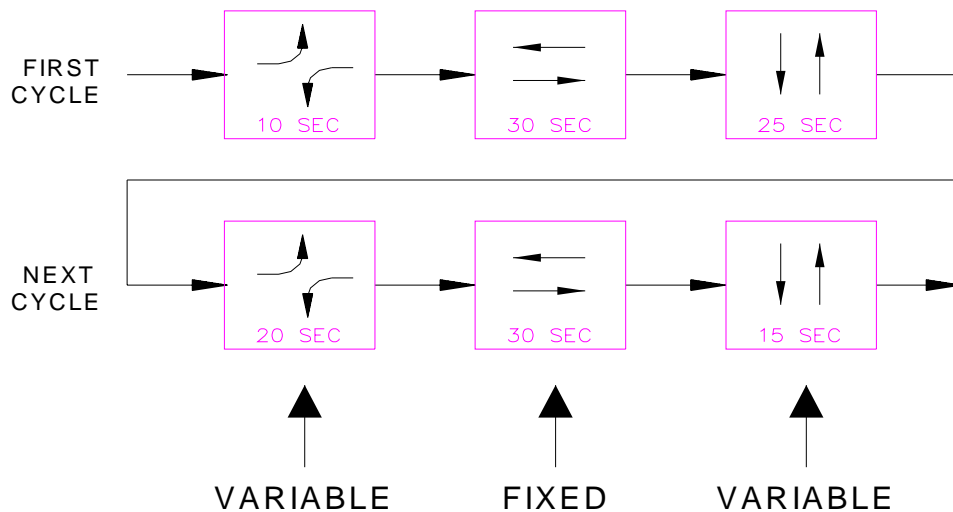

During a given time of the day, such as the AM rush hour, the green time provided to the side street phases and the main street left turn phases can increase or decrease depending on the amount of vehicular demand but the green time provided to the main street through movements remains fixed. Vehicle demand at a semi-actuated signal is monitored by detection devices located in the main street left turn lanes and on the side street approaches to the intersection.

In modern signal systems, pretimed control is almost exclusively reserved for compact networks of signals, such as those found in downtown areas, since pretimed control is required to produce the cross-coordination needed in compact networks. However, it should be recognized that some cities still have older signal equipment that is only capable of pretimed control. In these cities, pretimed control may be in use at locations outside of the downtown area, locations that would benefit from some form of actuated control.

It should also be recognized that some agencies consider the installation and maintenance of detection devices (such as inductance loops) to be too expensive so, without detection, pretimed control must be used.

Semi-actuated control is most commonly used in arterial signal systems. It is used to guarantee a certain level of coordination along the arterial while still permitting green times to vary with demand for both the main street left turns and the side street movements. For arterial signal systems it is common practice to use semi-actuated control during the majority of the day when there are significant platoons on the major street and providing progressed flow is important. Control is then switched to fully-actuated late at night when main street volumes drop and providing system coordination is not as important as providing maximum operational efficiency at the individual intersection.

Fully-actuated control is the most efficient form of signal control for non-coordinated intersections since it reduces to a minimum the amount of wasted green time.

The primary factor in locating the signal controller is the location of the source of electrical power for the signal. For our example intersection there is an existing overhead electric line running north-south along the east side of the intersection and a step down transformer is present on the utility pole located in the southeast corner.

Consequently, locating the signal controller in the southeast corner would be a wise decision:

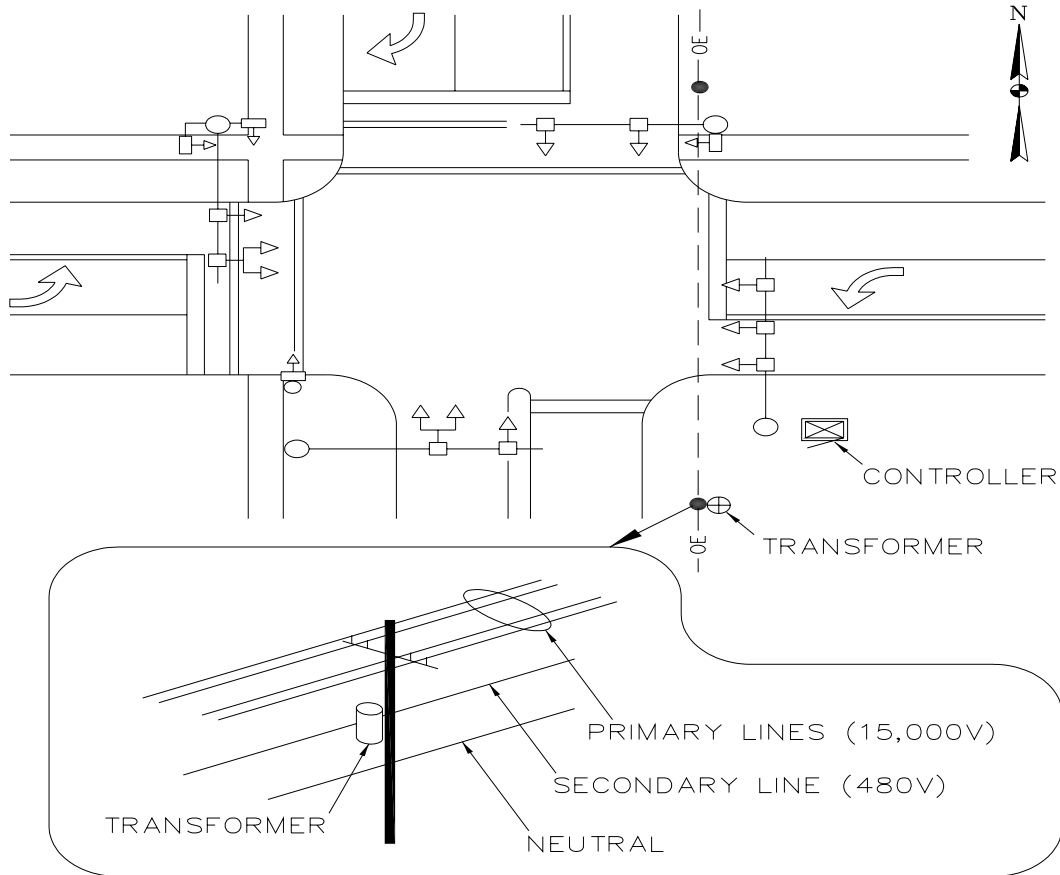

It is a good idea to meet at the intersection with a representative of the power company in order to identify the best source of power. There may be a good reason not to use a certain power source (the electric company plans on abandoning the line next month) or there may be another unseen power source at the intersection (such as an underground electrical vault). During this field meeting the type of electrical feed to the controller (overhead or underground) should also be agreed upon. Underground electric feeds are better looking, but cost more, since underground conduit and pull boxes must be installed.

Traffic signal controllers and their associated peripheral equipment (conflict monitor, cabinet, panels, etc.) are fairly expensive and it is good to protect this equipment from errant vehicles by locating the controller as far as possible from the roadway. If possible, it is also a good idea to shield the controller by placing it behind a pole or other fixed object. The controller cabinet, like all signal equipment, must be located within the existing right-of-way. If this is not possible then either right-of-way will need to be purchased from the abutting property owner or some form of permanent easement will need to be secured. Since obtaining right-of-way takes time and costs

money, a concerted effort should be made to stay within the existing right-of-way. It is permissible, but not desirable, to locate controller cabinets within a sidewalk. If it is necessary to locate a cabinet in the sidewalk then every effort should be made to maintain at least 3 feet of clear sidewalk width for pedestrians.

An electrical disconnect switch must be provided between the power source and the controller so that power to the intersection can be shut-off in the event of an emergency (such as a vehicle hitting the signal controller cabinet). It is usually preferable to locate the disconnect on a non-movable object, such as a signal support pole, so that it is protected from knock-down.

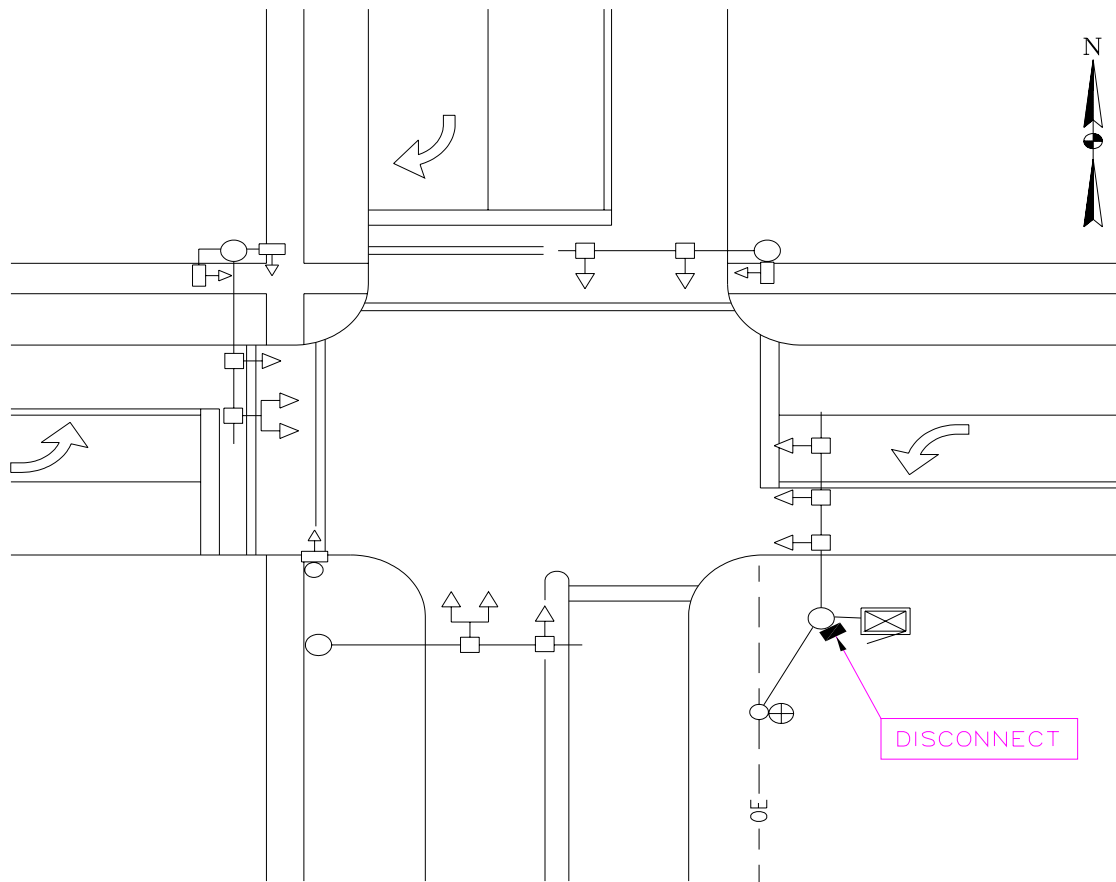

Locating the disconnect on the controller cabinet is not considered good practice since, if the cabinet is leveled by a car, then it will not be possible to shut off the live wires without getting the electric company involved.

The wire that goes from the power source to the cabinet via the disconnect is usually referred to as the "electric service wire".

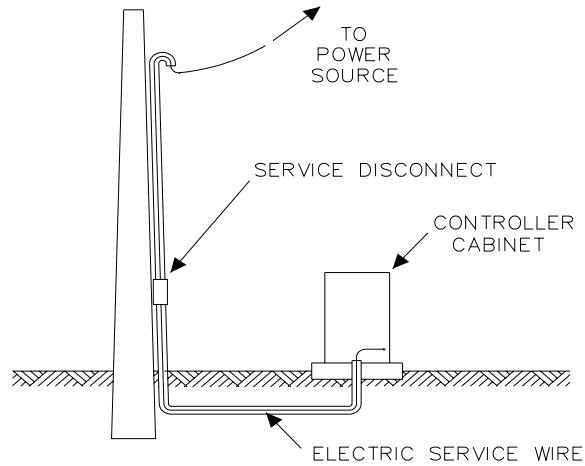

The electric service wire typically consists of 2 conductors, the black positive "power feed" wire and the white negative "neutral" wire. Sometimes a green ground wire is also provided.

If actuated control is selected for the intersection then the next step in the design process will be the design of the detection system:

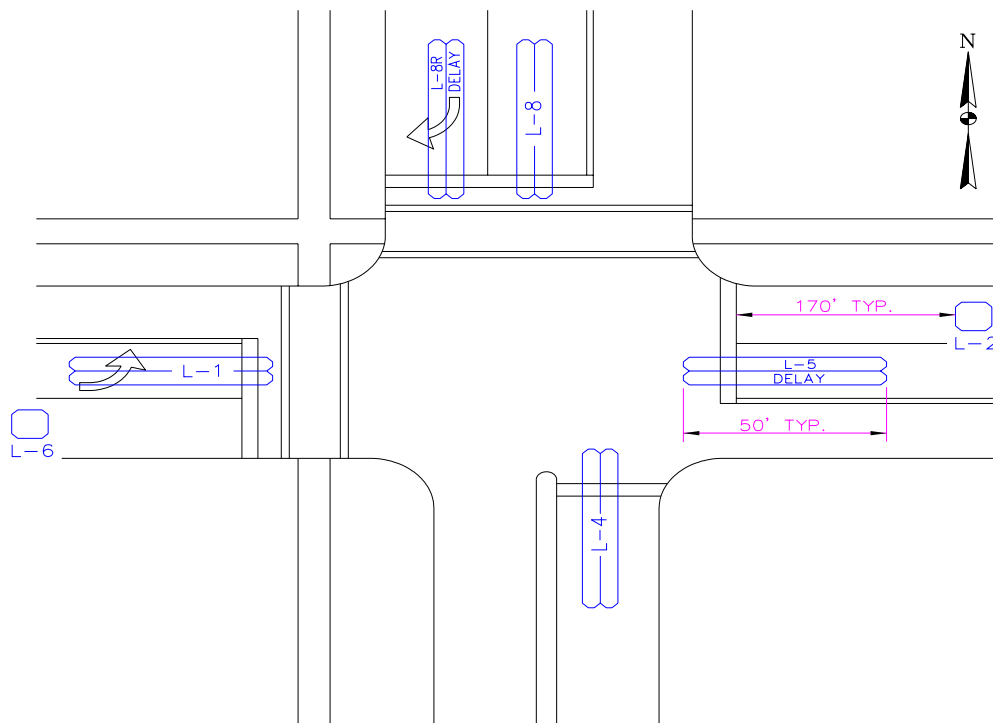

Decisions to be made include: the type of detection to be used (overhead, in the pavement, or under the pavement); the length of the various detection zones; and the location of the detection zones (upstream or stop line). Continuing our example signal design, detection using inductance loops cut-into the pavement has been added to the intersection.

50-foot long, stop line loops have been added in the main street left turn lane and on the minor street approaches while 6-foot long upstream loops have been placed in the major street thru lanes. Each loop is given a designation that corresponds to the phase it is associated with. For example, the south approach loop is associated with phase 4, so it is given the designation L-4.

The quality of the pavement where the loops are to be placed should be checked during design to ensure that a reasonable environment exists for the loops. Excessive cracking or spalling pavement does not make a good "bed" for loops, resulting in premature loop failure. If the pavement is in bad shape, the intersection may need to be resurfaced first or overhead detection (such as video detection) used instead.

In order to connect the signal heads, pedestrian heads, vehicle detection, and pedestrian pushbuttons to the "brain" of the intersection (the controller), and to the power source, wiring must be installed between the controller cabinet and each of these items. The wiring that goes between the controller and the signal heads (both vehicular and pedestrian) is referred to as signal cable. This wiring is usually in the form of jacketed multi-conductor cable (such as 16 conductors per cable). Signal cable operates at 120 volts AC and, with respect to a traffic signal installation, is considered "high voltage".

Although not necessary, it is common practice to have a separate cable from each loop assembly (or any other vehicular detection device) to the controller. Loop cable typically consists of two conductors located within a shielded jacket. Loop wiring operates at 24 volts DC and, with respect to a traffic signal installation, is considered "low voltage". Wiring that goes between the controller and each pedestrian button also operates at "low voltage" (24 volts DC).

Wiring is usually placed underground in plastic or metal conduit with a typical diameter of about 2 inches. Since it is somewhat expensive to install conduit, especially under existing pavement, conduit length should be kept as short as possible.

The following graphic shows an efficient conduit design for our sample intersection:

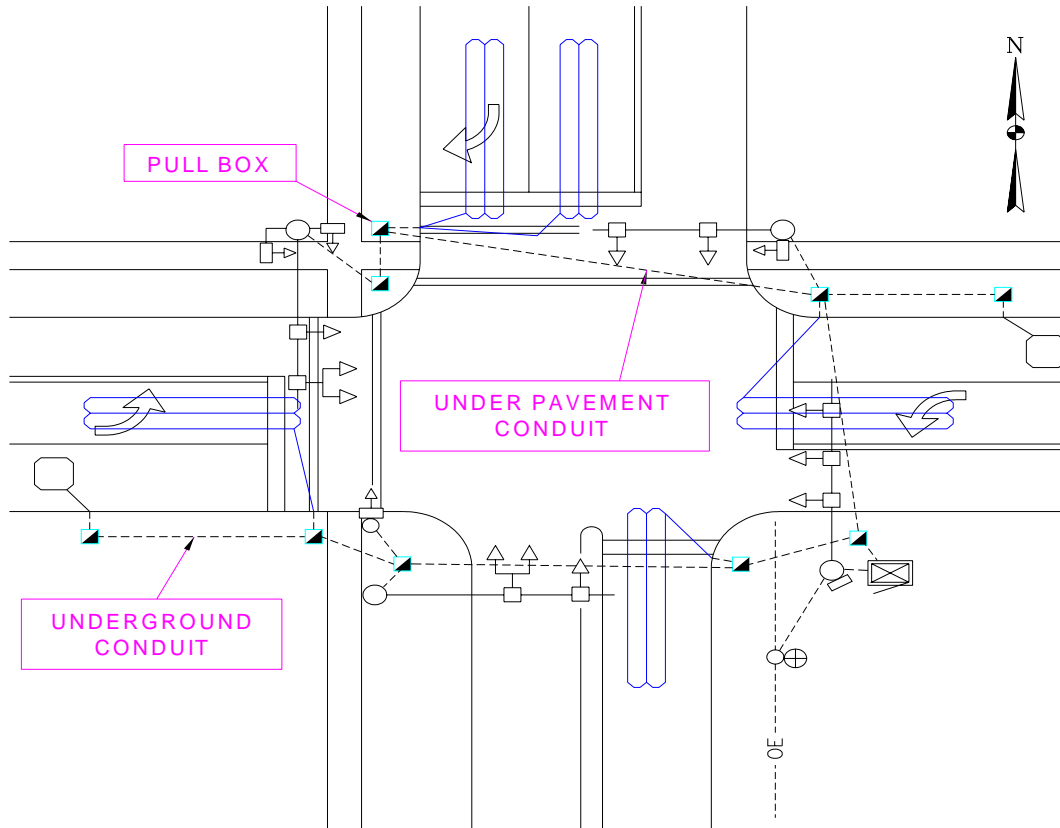

Many agencies like the idea of adding spare conduit runs during the initial installation of a signal in order to accommodate possible future expansion. Putting the spare conduit runs in "up front" is much less expensive, and less disruptive, than having to install additional conduits at a later date.

Pull boxes are primarily used where conduits come together or change direction. In long runs of conduit, pull boxes are installed every few hundred feet to allow access to the wire for installation purposes. A pull box might also be used where an underground splice is permitted, such as between inductance loop wire and shielded lead-in wire.

To avoid unwanted interference, the electrical service wire must be separated from other wires, especially low voltage loop and pedestrian button wires. This separation is accomplished by placing the electrical service wire in its own conduit. Although many agencies routinely mix signal cable and loop cable in the same conduit, other agencies prohibit this out of concern for potential interference. Some agencies go so far as to provide completely separate conduit and pull box systems for the "high voltage" and "low voltage" wiring.

REQUIRED TIMING INTERVALS

The following timing intervals must be determined for each phase of a traffic signal:

1. Yellow Interval
2. All Red Interval (if used)
3. WALK Interval (if pedestrian heads are used)
4. Flashing DON'T WALK Interval (if pedestrian heads are used)

The yellow change interval is typically calculated using the ITE formula:

$$Y = \frac{V}{(2xD) + (64.4xG)} + R$$

V = Speed (ft. per second)

D = Deceleration Rate (ft. per second²)

G = Grade (%), " + " if uphill, " - " if downhill

R = Reaction Time

The length of the yellow interval varies based on approach speed and grade. Downhill approaches with a high posted speed require the longest yellow intervals while uphill approaches with a low posted speed require the shortest. Basing the yellow interval on approach speed and grade ensures that all motorists receive sufficient time to negotiate the intersection during the change interval. To avoid safety problems and legal liability risks, it is recommended that the ITE formula be used to calculate the yellow interval.

A typical vehicle deceleration rate used in calculating the yellow interval is 10 ft/sec/sec and a typical reaction time is 1 second. If the approach speed is 45 mph (66 ft/sec) and the approach grade is 2% downhill, then the required yellow time is: $66 / [(2 \times 10) - (64.4 \times 0.02)] + 1 = 4.5$ seconds.

For motorists who have legally entered the intersection on the yellow, the all red change interval provides additional time for motorists to cross the intersection. It should be noted that provision of an all red interval is not mandatory and some agencies choose not to use one.

If pedestrian heads are used then, for each pedestrian phase, both the WALK and flashing DON'T WALK intervals will need to be determined. The WALK interval is typically a fixed value of between 4 and 7 seconds, enough time for someone to leave the curb, whereas the duration of the flashing DON'T WALK interval (also called the pedestrian clearance interval) depends on the length of the crosswalk and the walking speed of the pedestrians using the crosswalk, with 3.5 feet/second being the typical value used for design.

When pretimed control is used, another timing interval that must be determined is the green interval for each phase. These values are typically calculated using signal timing computer programs such as TRANSYT, SYNCHRO or SIDRA. In general, the more traffic volume per lane on a given approach, the more green time that approach will receive in comparison to other approaches.

When actuated control is used, the amount of green time for a given movement varies from cycle to cycle. Consequently, there is no fixed green interval to calculate. Instead, the designer must decide on the timing to be used for three separate intervals:

1. The Initial Interval,
2. The Passage (or Extension) Interval, and
3. The Maximum Interval

Existing computer programs are of little help in setting these actuated intervals. The designer must rely on engineering judgment and experience with similar installations in order to select efficient timing values.

COORDINATED SIGNAL SYSTEM TIMING

A platoon is a bunched grouping of vehicles that travels in the same direction through a coordinated system of signals. The goal of coordinated signal system timing is to provide timings which allow platoons to travel in both directions along the arterial without stopping, or with a minimum number of stops, and to do so without forcing motorists on the side street to wait too long. In order to progress platoons along the arterial a whole host of timings must be decided upon when designing a series of coordinated signals. These include: cycle lengths, offsets, force offs, permissive periods, time-of-day plans, week plans, and so on. Sophisticated computer programs, such as TRANSYT and SYNCHRO are often used to help the designer select these timings.

Much of the data collected during the planning stage of the signal design can also be used for the calculation of traffic signal timings. Such information as hourly traffic volumes, number of lanes by approach, and the percentage of trucks is used as input for the signal timing computer programs. An important input that will need to be calculated using traffic volume data is the Peak Hour Factor (PHF) for each movement. The PHF is obtained by dividing the peak hour volume by 4 times the highest 15 minute volume. It is an indication of the level of traffic surging that occurs within a given hour. Low peak hour factors indicate high levels of surging. Typical PHF values range between 0.75 and 0.95. A PHF value of 1.00 indicates that there is uniform traffic flow throughout the hour with no surging.

Whatever timings are developed as part of the design work, it is almost certain that they will need some adjustment to match field conditions. This is especially true for coordinated signal system timings. It should be emphasized that considerable judgment and experience is needed to develop good signal timings, especially coordinated signal system timings.

DESIGNING THE COMMUNICATIONS SYSTEM

If a new signal is added to a traffic signal system, such as a closed-loop or hybrid system, then it will probably be necessary to install a communication system to connect the new signal with the closest signal in the system. In designing the communication system, the first decision that will need to be made is whether or not the communication system will be a wireless one, such as a spread-spectrum radio system.

If it is decided not to install a wireless system then some form of interconnect cable will need to be run between the new signal and the closest signal in the system. If there is room on the poles, this line can be installed overhead on existing utility poles. However, if there is insufficient room, then

the line will have to be installed underground in conduit. In designing a hard-wire interconnect system, a decision will need to be made as to the type of interconnect wire to be used. Options include multi-pair copper cable, coaxial cable, and fiber optic cable. Most modern communication systems use fiber optic cable because of its ability to carry large volumes of data, such as that required for real-time traffic video feeds.

In order to integrate the new signal into the existing system, special communication-related devices will be needed in the controller cabinet and the controller itself may require special software.

Since most communication lines are particularly sensitive to interference, it is standard practice not to mix communication cable with any other type of cable. The exception to this rule is fiber-optic cable, which is unaffected by electromagnetic interference and can be run in the same conduit with any type of cable.

ACCOMMODATING INDIVIDUALS WITH SPECIAL NEEDS

It is important that a traffic signal installation not only serve the average motorist and pedestrian but also serve those motorists and pedestrians that have special needs, such as the elderly and the physically challenged. Use of the following items makes it easier for the elderly and those with visual acuity problems to negotiate a signalized intersection:

- 12-inch diameter signal lenses (instead of 8-inch),
- Supplemental signal heads,
- 6-inch wide lane lines (instead of 4-inch),
- Overhead street name signs with large letters,
- Advanced street name signs,
- Overhead-mounted signals (instead of pedestal mount),
- Fiber optic blank out signs, and
- Protected-only left turn phasing,

As people live longer, and as the baby boomers retire, the number of "senior" drivers continues to go up and the ability to safely accommodate the needs of these older drivers becomes increasingly important.

Use of the following items make it easier for elderly pedestrians and those with physical limitations, including individuals in wheelchairs and those with serious sight deficiencies, to negotiate a signalized intersection:

- Accessible curb cut ramps (instead of barrier curb),
- Tactile surfaces (that warn blind pedestrians of a crossing),
- Pedestrian pushbuttons with locator tones and tactile arrows
- Pedestrian signals with audible and vibrotactile indications,
- 10-foot wide crosswalks (instead of 6-foot wide),
- WALK intervals set at their maximum value (7 seconds or more), and
- Flashing DON'T WALK intervals calculated using a slow walking speed (such as 3 feet per second).

Those with physical impediments often cannot drive and are therefore more dependent on a user-friendly pedestrian system. Unfortunately, serving those with special needs does not come without a cost, either in terms of construction dollars or degradation of the operational efficiency of the intersection. A wise approach is to identify improvements that are the most cost-effective and then implement those improvements first.

Although it is desirable to serve individuals with special needs, the temptation to design traffic signals so conservatively that the average motorist becomes frustrated with their operation and loses respect for the traffic control system as a whole should be avoided. Such items as overly restrictive left turn phasing and inordinately long pedestrian intervals can produce such motorist disrespect.